



**PRODUCT**  
**CATALOGUE**

2026



History & Features



10 Window Cleaning



28 Soft Washing



32 Roof Cleaning

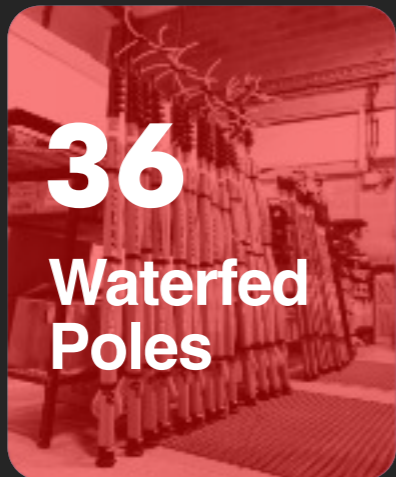

36 Waterfed Poles



38 Hose Reels & Gutter Cleaning

# About Us

The company that changed the window cleaning industry.

For 12 years we were expert window cleaners, and for the past 25 years we've continued to draw on that expertise to deliver ground breaking Reach & Wash® products that make window cleaning safer, faster and more profitable for our customers. **This is why we remain No.1 in the market.**

The Reach & Wash® logo depicts an athletic figure created from water using a waterfed pole for cleaning. The logo reminds us that it is actually the water that is doing the work.

Once you understand that, then like us you'll realise the purer the water the faster and better the cleaning results will be. Uniquely, Ionic Systems offers the very best water quality out of all competing products.

However, it's no longer just window cleaning that we have become specialised in. We now offer a range of Soft Washing and Roof Cleaning systems, namely the Foamion® and Roof Wand®.

No matter what we create, we apply the same Ionic ethos to all of our products.



**Quality. Safety. Efficiency.**

If a product doesn't match these values, it is not an Ionic Systems Reach & Wash® product.

For more information, videos and technical specifications please visit our website [ionicsystems.com](http://ionicsystems.com)



# Through the years...

We've hit many milestones and released many bestsellers over the years, have a look at some of our proudest moments.

## 1997

Over The Top (OTT) invents the Reach & Wash™ system and the British Window Cleaning Academy (BWCA) is launched.



## 2002

Ionic launches the 'Thermopure'. The very first hot water Reach & Wash™ system. It quickly won the approval of window cleaners, fast becoming one of our most popular systems.



## 2001

'Over the Top Ltd' changes its name to 'Ionic Systems Ltd', reflecting the change in focus of the business.



## 2003

Ionic launches the 'ERGOLITE' range of waterfed poles, developed to be lighter, more rigid and narrower in response to new HSL recommendations.

This was also the year we completed full crash testing of our van mounted systems. We remain to be one of the only suppliers to achieve the FMVSS-208 safety standard.

## 2006

Ionic develop and release the Pro-6 system. Reducing water consumption by 50%, the Pro-6 is one of the finest window cleaning systems available.



## 2005

New UK regulations severely restrict the use of ladders, causing unprecedented numbers of window cleaners to convert to the Reach & Wash™ system.

## 2009

'TRANSVERSE' clamps are fitted to Ionic poles. They are smaller, lighter and grip the poles more evenly. The 'GLYDER pole was released a year later.



## 2012

Zero™ by Ionic Systems is launched. With fully automated flushing and regen cycle, 8-stage filtration and 18 meg-ohm water at OPPB - the Zero™ is the simply the best system available.



## 2021

Ionic has developed and released the Roof Wand™, the safest and most effective method of cleaning a roof, utilising the same concept as the Reach & Wash™ system.



## 2023

Ionic continues to innovate, with the release of the Foamion Portable, unveiled at the London Cleaning Show 2023.



## 1998

OTT pioneers the use of waterfed poles and pure water for window cleaning.



## 2014

Ionic moves into a brand new 22,000 sq ft building, suited for the increased level of production to meet demand.



## 2020

Ionic Systems release the Foamion™ Softwashing system as an extension unit for a pre-existing Reach & Wash™ system. Foamion™ makes it easier for window cleaners to diversify and expand their business.

## 2022

Ionic celebrates its 25<sup>th</sup> year of business and continues to innovate and push the market. Following the years after the COVID-19 pandemic, Ionic Systems remains a market leader due to its ability to proactively adapt and respond to the industry.

## 2025

Our latest portable pure water system; more powerful than ever. Able to provide 10 lpm to up to 4 operators or a single solar cleaning robot. A world's first in scalable window cleaning operations.





## Train online. Master on-site. Get Certified with the BWCA.



### Roof Cleaning

Learn how to clean roofs from the safety of the ground using the revolutionary Roof Wand. All practical, onsite based.



### Soft Washing

Designed for all skill levels. Complete the theory online, in your own time. Then join us for a morning session onsite where you can master the practical elements of softwashing.



### Window Cleaning

Appropriate for beginners to seasoned professionals looking to sharpen their skills. Learn the key fundamentals of pure water window cleaning & apply the practical elements in-person.

# 20% OFF DISCOUNT

Purchase 2 or more courses to apply a 20% discount!

Visit our website for more

## [bwca.co.uk](http://bwca.co.uk)

## Safety: Our Core Commitment

At Ionic, we are unwavering in our commitment to ensuring the highest levels of safety for our customers. We understand that trust is the cornerstone of our relationship with you. This is why safety isn't just a feature of our products; it's the foundation of everything we do. From rigorous crash testing, to achieving top safety ratings and innovating with electrical safety features like insulated pole handles, our dedication to safety is all-encompassing.

### Innovating for Electrical

Despite the best efforts of the window industry to warn window cleaners about the risk of electrocution; too many have lost lives or suffered serious burns whilst using waterfed poles near overhead power lines. Ionic Systems is the only manufacturer to have developed a waterfed pole to address the risk of electrocution, certified to British Standard 8020:2011 and tested in a laboratory capable of testing up to 100,000 volts. As a result, our carbon fibre poles are safe for use up to 50,000 volts and our glass fibre poles up to 80,000 volts.



### Unparalleled Crash Testing

Following these tests and the chassis design and installation changes that resulted, 100% impact barrier tests at 31.1mph were conducted as required for FMVSS-208 certification.

### Our Promise to You

Ionic's commitment to safety is unwavering. It's not just about meeting safety standards; it's about setting new benchmarks for safety in the industry. We pledge to continue innovating and investing in safety technologies that protect our customers, and enhance their confidence in our products. With Ionic, you can rest assured that safety is always our top priority.

# Features

Take a look at the features that make an Ionic system the best available on the market.



## Automation

We have a range of patented automation technologies specifically designed to make the functioning of our systems as seamless as possible.

### ROMS™

#### Reverse Osmosis Maintenance System.

At the end of each tank fill, pure water is diverted to the RO membrane, leaving it bathed in pure water rather than high TDS tap water.

### PFS™

#### Periodic Flush System

On start up, this feature automatically flushes the reverse osmosis membrane for 2 minutes. Thereafter, the RO is flushed for 2 minutes every hour during the filling process.



## Stainless Steel Construction

All of our machines are built using high quality stainless steel. We use this material because it is non-corrosive, meaning it will never rust, and is extremely robust.

We offer a 10-year warranty guarantee on our stainless steel frames.



## After sales Support & Training

We are one of the only exterior cleaning systems manufacturers to offer complete after sales support & training.

Partnered with the BWCA, we provide extensive training on the use of our products, as well as teaching customers how to successfully grow their business.



# Vehicle Set-Out Options

Choosing the right vehicle and customising it to your businesses needs is very important. Read below for some useful information to consider when choosing a vehicle.



## Vehicle floor protection

We highly recommend our vehicle floor protection services to all of our customers. We apply a hard wearing, waterproof lining that protects your vehicle from rust, damage and water ingress.

Lining is applied to the vehicle floor and lower section of the sides for maximum protection. Water simply runs off without ever coming into contact with the paintwork.

Small Vans

Medium Vans

Large Vans



## Charging options

We highly recommend purchasing an on-board battery charger for your system. This battery charger will enable automatic charging of the system's leisure battery through the driving of your vehicle.

Modern "stop-start" vehicles will need a "battery-to-battery" charger, whilst older vehicles generally use a "split charger".

## Vehicle Payloads

Your choice of vehicle will dictate what cleaning system you will be able to carry. Here we have created a table to show you what payload of vehicle will be necessary depending on the size tank system you purchase.

300L	400L	500L	600L	700L	800L	900L	1000L
600kg	700kg	1000kg	1100kg	1200kg	1300kg	1400kg	1500kg

300L & 400L systems payload is based on the van having a single operator, 1 hose reel & pole.  
500L systems & larger payload is based on twin operatives, 2 hose reels & selection of poles.

## Pole racks

Stainless steel pole racks can be fitted to your finished vehicle. These provide a sturdy and professional looking storage for your waterfed poles.



Roof Mounted  
(Low Roof)

Roof Mounted  
(High Roof)

Side Mounted

## Water Port Options

Don't want to leave your van open when filling or operating your system? Our stainless steel water ports allow for seamless use. Available as side ports or under mounted rear ports.





**The Zero™ system represents the ultimate in pure water window cleaning systems.**

It was back in 1997 that Ionic Systems introduced The Reach & Wash® System. We told the world of window cleaning that water of zero parts per million (0ppm) was the standard required for spot free results. Yet in truth waterfed poles are not magic wands, and both cleaners and customers alike sometimes experience windows left with less than perfect results.

Fifteen years later Ionic's new 'Zero' produces ultra pure water at zero parts per billion (0ppb), and that represents the gold standard. Water at 0ppb is 1,000 times purer than water at 0ppm, and because pure water cleans by dissolving dirt ions, it follows that water at 0ppb is capable of dissolving 1,000 times more dirt than water of 0ppm.

Other systems remove only dissolved solids from the water supply, uniquely the Zero® removes both dissolved solids and all organics, as well as bacteria from the water supply. The result is not only water that is 1,000 times purer but also ultra pure water that is free from micro-organisms such as legionella bacteria and the organic matter that bacteria feeds upon. A significant benefit is that biofilm cannot form upon the surface of filter media, or the RO membrane. That means that filters maintain day one performance, which in turn means lower running costs.

Cleaning with 18meg-ohm (0PPB) water is a breeze, powering through years of baked on dirt and the dulling effects of pollution on glass. Whether its an initial clean, or a reduced frequency clean, the Zero™ is the system of choice to deliver spot free results in the shortest time.



Scan the QR Code for more information about the Zero and 0PPB water!



# Features

Take a look at the features that make the Zero™ system the best available on the market.



## 8-Stage Filtration

-  Delonisation
-  Reverse Osmosis x2
-  5µm Sediment Filter x2
-  Carbon Filter
-  NGDI Filter
-  UV + Ozone Filter

### Heated Water

The Thermopure™ upgrade enables the use of heated water.

### 230v Boosted Fill

A standard feature on all Ionic machines. Allows for significantly faster filling.

### 150 Ah Battery

The Zero is powered by a high capacity lead acid battery. Lithium ion battery is optional.

### Stainless Steel Chassis

Like all Ionic cleaning systems, this model is built with a stainless steel, non-corroding, ever lasting chassis. Comes with a 10-year warranty.

### Fully Automated Flush Cycle

The Zero™ has fully automated PFS™, & ROMS™ features that allow you to simply connect your mains water to the system at the end of the day and the system will take care of the rest.

### Digital Flow Control

Auto-compensating digital flow control allows precise operation of the pumps.

### Twin Pumps

The Zero™ has two independently controlled pumps allowing more than one pole to be used at the same time.

### Dual TDS Monitoring

The TDS of the water at critical stages is monitored.

### Easy Refillable Filters

The filter media cartridge is simply replaced when spent.

## Zero™

The Zero™ represents the very best system for your window cleaning business. (Pure water production up to 6 litre's per min dependent upon mains water supply). Complete with fully baffled black polypropylene tank and stainless steel construction for full vehicle stability. Includes temperature & tank sight gauge, as well as integrated battery charger.

### Prices & Finance

- Zero parts per Billion
- Zero™ PPB System 500 Litre
- Zero™ PPB System 600 Litre
- Zero™ PPB System 700 Litre
- Zero™ PPB System 800 Litre
- Zero™ PPB System 900 Litre
- Zero™ PPB System 1,000 Litre

### Upgrades

Thermopure

## Zero™ 'S'

All the features of the Zero™.

However, the 'S' model also features our high performance stainless steel filter housings to turbo charge pure water production. The 'S' model is highly recommended for use in countries where summer temperature's rise above 35 degrees C.

### Prices & Finance

- Zero parts per Billion
- Zero™'S'PPB System 500 Litre
- Zero™'S'PPB System 600 Litre
- Zero™'S' PPB System 700 Litre
- Zero™'S' PPB System 800 Litre
- Zero™'S' PPB System 900 Litre
- Zero™'S' PPB System 1,000 Litre

### Upgrades

Thermopure

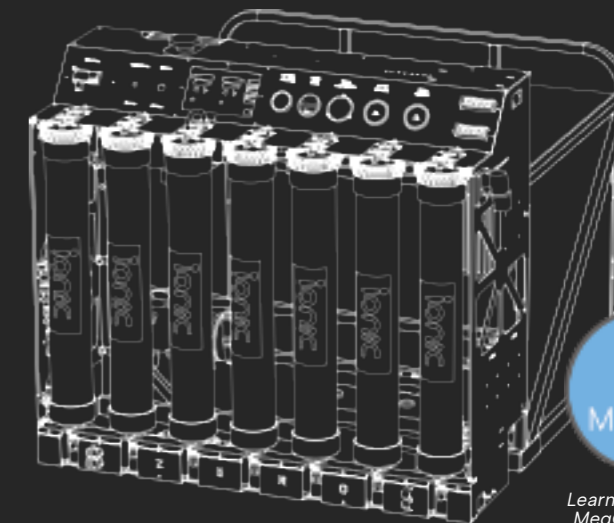

18  
MEGΩ

Learn more about  
MegOhm on our  
website!

Dimensions (mm):  
500L, 600L & 700L = H 1065 x W 1224 x D 1300  
800L, 900L & 1000L = H 1065 x W 1224 x D 1450

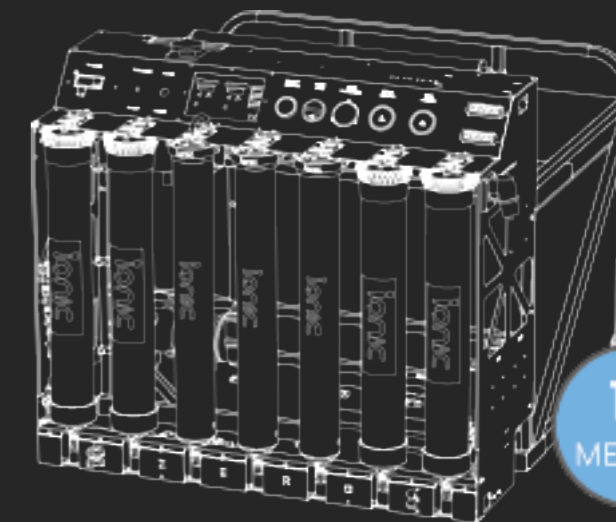

18  
MEGΩ

Dimensions (mm):  
500L, 600L & 700L = H 1065 x W 1224 x D 1300  
800L, 900L & 1000L = H 1065 x W 1224 x D 1450

# V4

The V4™ Thermopure fills the gap between the Zero™ with 0PPB water quality and Ionic's cold water V4™.

The name V4™ signifies version four of the original Reach & Wash® system, and previously if you wanted hot water then your only option was to run a HotBox™ alongside.

Now rolled into one great looking, space saving package the V4 Thermopure™ has the look of the more expensive Zero™, but with a lower price tag.

The all stainless steel construction will remain corrosion free, outlasting your vehicles many times over. A crash tested Ionic system will last the whole of your window cleaning career, and prove to be by far the most cost effective choice. Just like the standard V4™ the Thermopure™ version can be configured with boosted fill, and a range of automation features to suit your individual needs and price point.

V4 Thermopure™ is technically superior in many ways too. The 9 kilowatt diesel powered water heater draws its fuel from the vehicles own fuel tank. Purified water produced by the industrial sized water

filters stored in the perfectly baffled holding tank can either be heated on demand, or can be heated more economically by preheating the pure water prior to use. As well as reducing fuel consumption preheating also comes with the benefit of preventing winter frost damage to system components and a frost free windscreen!

The system cleverly optimises performance of the diesel heater, by avoiding cycling constant temperatures are maintained on both the summer and winter settings.

Provided the instructions are followed, many years of service can be expected. Many of our early Thermopure™ customers are still operating their original machines today, opting to move their machine into their next van!



Scan the QR Code  
for more  
information!



# Features

Take a look at the features of the V4™ Hot and Cold water systems.



Pictured above: V4 Thermopure™ hot water system.

## 4-Stage Filtration

-  Deionisation
-  Reverse Osmosis
-  5-Micron Filtration
-  Carbon Filter

### Easy Refillable Filters

The filter media cartridge is simply replaced when spent.

### Dual TDS Monitoring

The TDS of the water at critical stages is monitored.

### Twin Pumps

Two independently controlled pumps allowing more than one pole to be used at the same time.

### Fully Automated Flush Cycle

The V4™ has fully automated PFS™, & ROMS™ features that allow you to simply connect your mains water to the system at the end of the day and the system will take care of the rest.

### Stainless Steel Chassis

Like all Ionic cleaning systems, this model is built with a stainless steel, non-corroding, ever lasting chassis. Comes with a 10-year warranty.

### Digital Flow Control

Auto-compensating digital flow control allows precise operation of the pumps.

### 230v Boosted Fill

A standard feature on all Ionic machines. Allows for significantly faster filling.

### 100Ah (Cold) & 150Ah (Hot) Battery

Powered by a high capacity lead acid battery. Lithium ion battery is optional.

## V4 Fusion™

FUSION™ is a high performance, fully automatic four-stage RO/DI system with 240v mains powered boosted fill. PFS™ & ROMS™ are all standard features on the Ionic FUSION™ System. (Pure water production up to 3 ltrs per min dependent upon mains water supply). System includes integrated mains battery charger, tank sight gauge and a fully baffled water tank.

### Prices & Finance

V4™Fusion	300 Litre
V4™Fusion	400 Litre
V4™Fusion	500 Litre
V4™Fusion	600 Litre
V4™Fusion	700 Litre
V4™Fusion	800 Litre
V4™Fusion	900 Litre
V4™Fusion	1,000 Litre

## V4 Fusion™ 'S'

FUSION 'S'™ is an ultra high performance system designed for the most demanding customers, as well as the world's hottest climates. With fully automatic four-stage RO/DI system with 240v mains powered boosted fill. PFS™ & ROMS™ and of course stainless steel filter housings, all standard features on the Ionic FUSION 'S'™ System. (Pure water production up to 5 ltrs per min dependent upon mains water supply).

### Prices & Finance

V4™Fusion 'S'	300 Litre
V4™Fusion 'S'	400 Litre
V4™Fusion 'S'	500 Litre
V4™Fusion 'S'	600 Litre
V4™Fusion 'S'	700 Litre
V4™Fusion 'S'	800 Litre
V4™Fusion 'S'	900 Litre
V4™Fusion 'S'	1,000 Litre

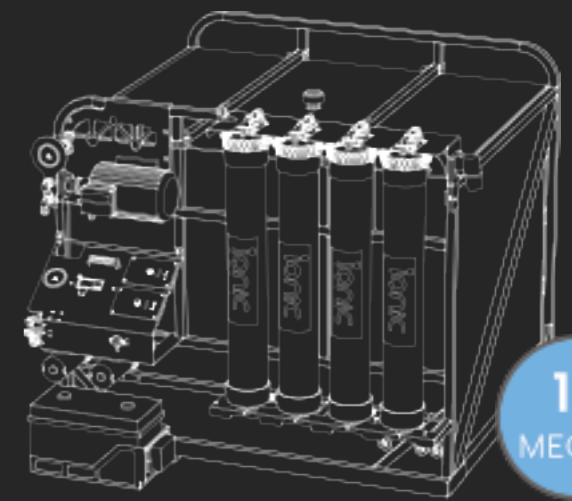

Dimensions (mm):  
 300L & 400L = H 1065 x W 1129 x D 880  
 500L, 600L, 700L = H 1065 x W 1224 x D 1110  
 800L, 900L, 1000L = H 1065 x W 1224 x D 1260

12  
MEGΩ

Learn more about MegOhm on our website!

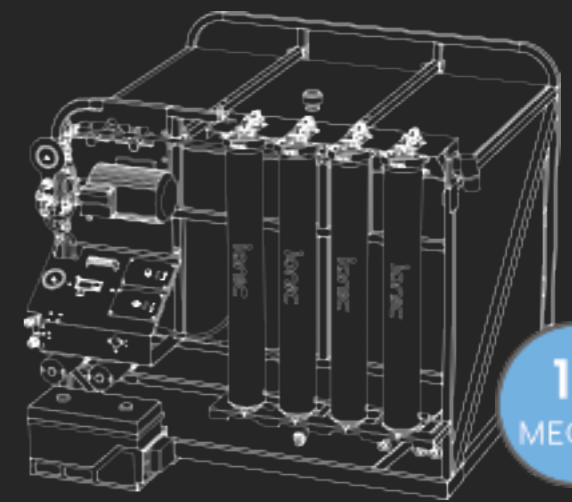

Dimensions (mm):  
 300L & 400L = H 1065 x W 1129 x D 880  
 500L, 600L, 700L = H 1065 x W 1224 x D 1110  
 800L, 900L, 1000L = H 1065 x W 1224 x D 1260

15  
MEGΩ



## V4 Thermopure™

The industry leading large capacity filters used on the V4 Thermopure™ ensure the highest quality pure water filtration, combined with ease of maintenance and low running costs. With the addition of Ionic's 9kw diesel powered pure water heating system the V4 Thermopure™ becomes a powerful 4-season window cleaning system, busting stubborn dirt all year round. All the features of the Fusion model, but with the integrated extension of hot water.

### Prices & Finance

V4™Thermopure 500 Litre  
 V4™Thermopure 600 Litre  
 V4™Thermopure 700 Litre  
 V4™Thermopure 800 Litre  
 V4™Thermopure 900 Litre  
 V4™Thermopure 1,000 Litre

## V4 Thermopure™ 'S'

All the features of the standard V4 Thermopure™ model, with the added benefit of stainless steel filter housings. The 'S' model is highly recommend for use in countries where summer temperatures rise above 35 degrees C.

### Prices & Finance

V4™Thermopure 500 Litre  
 V4™Thermopure 600 Litre  
 V4™Thermopure 700 Litre  
 V4™Thermopure 800 Litre  
 V4™Thermopure 900 Litre  
 V4™Thermopure 1,000 Litre



12  
MEGΩ

Dimensions (mm):

500L, 600L, 700L = H 1065 x W 1224 x D 1290  
 800L, 900L, 1000L = H 1065 x W 1224 x D 1440



15  
MEGΩ

Dimensions (mm):

500L, 600L, 700L = H 1065 x W 1224 x D 1290  
 800L, 900L, 1000L = H 1065 x W 1224 x D 1440

# STATIC SYSTEMS

We offer static pure water systems combined with our bestselling Zero© & V4© window cleaning machines. These systems work in the exact same way as a vehicle mounted system, just fixed to one location.

For the cost of one system, you can supply several fleet vehicles with pure water at either 0PPM or 0PPB.

PPB  
**ZERO**



## Polypropylene Tank

Robust black plastic polypropylene tank will inhibit the growth of algae. Available in multiple sizes.

## Control Panels

The control panels look and function exactly the same as our vehicle mounted systems. Complete with all automation features.

## Ionic Refillable Filters

Ionic filters using either stainless steel or polymer housings.

**V4**

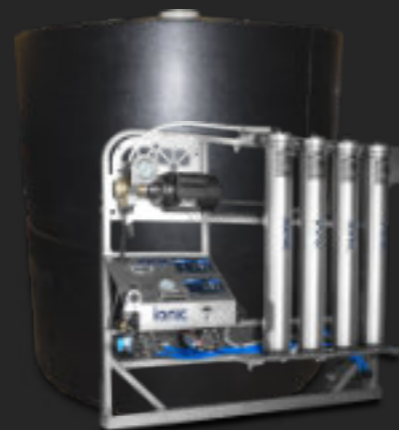

**Zero™**  
Dimensions (mm):  
H 1065 x W 1224 x D 420

**V4™**  
Dimensions (mm):  
H 1065 x W 1224 x D 330



Scan the QR Code for more information!

Zero  
Zero S  
V4 Fusion  
V4 Fusion S

# DELIVERY SYSTEMS

Stored pure water is then transferred into the tank of a “delivery system which is installed in a van or trailer. Delivery systems are designed just to ‘deliver’ the pure water, i.e. they have little or no water treatment on-board, but have the same crash tested chassis and control gear as our other systems.

The Thermopure™ delivery system can heat the water using a diesel burner before pumping it to the pole, and is our most popular delivery option.



**Thermopure™**  
Delivery Systems  
Hot Delivery 500 Litre  
Hot Delivery 600 Litre  
Hot Delivery 700 Litre  
Hot Delivery 800 Litre  
Hot Delivery 900 Litre  
Hot Delivery 1,000 Litre

**Thermo Delivery**  
Dimensions (mm):  
500L, 600L & 700L =  
H 1080 x W 1224 x D 1080  
800L, 900 & 1000L =  
H 1080 x W 1224 x D 1330

## Polypropylene Tank

Robust black plastic polypropylene tanks available in multiple sizes, fit for your businesses needs.

## Digital Flow Controls

Auto-compensating digital flow controls allows precise operation of the pumps.

## FMVSS-208 Compliant

All Ionic vehicle mounted machines are fully crash tested to the FMVSS-208 standard.



**Cold Water**  
Delivery Systems  
Cold Delivery 300 Litre  
Cold Delivery 400 Litre  
Cold Delivery 500 Litre  
Cold Delivery 600 Litre  
Cold Delivery 700 Litre  
Cold Delivery 800 Litre  
Cold Delivery 900 Litre  
Cold Delivery 1,000 Litre

**Cold Delivery**  
Dimensions (mm):  
300L & 400L =  
H 1065 x W 1129 x D 880  
500L, 600L & 700L =  
H 1065 x W 1224 x D 1065  
800L, 900 & 1000L =  
H 1065 x W 1224 x D 1260

# PORTABLE SYSTEMS

Robust on demand systems perfect for an on site maintenance team with access to water and power.

Ionic Systems offer on site solutions using the same Reach & Wash® style of system. They are powerful enough to deliver pure water to up to two waterfed poles, so that multiple operators can clean at the same time. Portable systems require a water and mains power supply, and its boosted pump provides enough power for a steady supply of water up to 80ft in height.

Portable systems are ideal for a range of applications where access is limited, including courtyards, rooftop and atrium cleaning, as well as use in combination with cradles and rope access.

Our range of portable systems are a compact yet powerful point of use system, capable of producing up to 6 litres of pure water per minute, bringing the benefits of spot free cleaning to a wide range of applications.

Utilising the same water purification technology found in our vehicle mounted and static systems, our portable window cleaning range packs a serious punch!



Scan the QR Code for more information!



On site building maintenance teams use Ionic portable systems for in house window and façade cleaning duties as well as spot free car washing.

Lightweight and easy to transport, our portable range can be taken almost anywhere making it a truly flexible and versatile system with many uses. Our portable systems are also widely popular amongst high level abseiling crews.

# QUATTRO™



### 4-Stage Filtration

-  Deionisation
-  Reverse Osmosis
-  5-Micron Filtration
-  Carbon Filter

**The Quattro™** – is available in three configurations. The standard Quattro works from water pressure alone (min 60psi), and is suitable for a single operator to use at lower levels.

**The Quattro™ Electric** - uses a 240V (or 110V) pump to boost the water pressure, and can be used to clean to 80ft for a single operator (2 lpm).

**The Quattro ‘S’** - All the features and benefits of the Quattro Electric system, but with stainless steel filter housings. This allows for 2 operators to work from this one unit at a time (4 lpm).

### Prices & Finance

[Quattro™ System](#)

[Quattro™ Electric System](#)

[Quattro-S™ Electric System](#)

# TRION



### 3-Stage Filtration

-  Deionisation
-  Reverse Osmosis
-  Carbon Filter

Incorporating a powerful 240V (or 110V) mains electric pump, Trion™ can supply pure water to multiple waterfed poles even when water pressure is relatively low (4 lpm).

Trion™ incorporates a highly efficient 40” reverse osmosis membrane, as well as Deionisation and Carbon filters. It’s capable of producing pure water economically, even when the local water is hard.

### Prices & Finance

[Trion™ System](#)

[TDS Meter upgrade](#)

# MACRO

### Engineered for high flow performance

Ideal for multi operator teams, the Macro can supply up to four poles simultaneously without compromising on pressure or water quality - making it the perfect solution for commercial window cleaning and feeding solar panel cleaning robots on large scale or high rise jobs.

With a robust stainless steel frame and RO housing, the Macro is built for tough environments. Its portable design gives you access to hard to reach areas like rooftops, courtyards, and remote locations where vehicle mounted systems can’t go.

### Key Features:

- **High Pressure Stainless Steel RO Housing**  
Durable and corrosion-resistant, designed for high output and maximise water production.
- **Dual 4040 Reverse Osmosis Membranes**  
Removes up to 99% of dissolved solids from tap water.
- **30" Carbon Filter**  
Removes chlorine to protect the RO membranes and extend system life.
- **30" De-ionisation Filter**  
Polishes the water to a flawless 0ppm, ideal for streak free cleaning.
- **240v or 110v Mains-Powered Pump**  
A 550w motor delivers outstanding flow and can be run via a compact generator.
- **Built-in TDS Meter**  
Real time water quality monitoring to ensure consistent performance.
- **Dual Operator Outlet**  
Fitted with two dual pole connectors - easily run up to four operators at once.



### 4-Stage Filtration

-  Reverse Osmosis x2
-  Deionisation
-  Carbon Filter

**0ppm**

Ultra pure water, for professionals who demand the best.

### Prices & Finance

[Macro™ System](#)

**10 lpm**

Maximum performance with our highest water output to date.

# ADDITIONAL EQUIPMENT



Dimensions (mm):  
H 610 x W 610 x D 420

## HotBox™

The HotBox™ uses the same diesel burners as our Thermopure™ Systems, and are capable of hot water within minutes of activation. The HotBox™ is powerful enough to provide piping hot water all year round. Includes 100Ah leisure battery and 15Ah mains charger.

### Ordering & Prices

Hotbox 9 kW

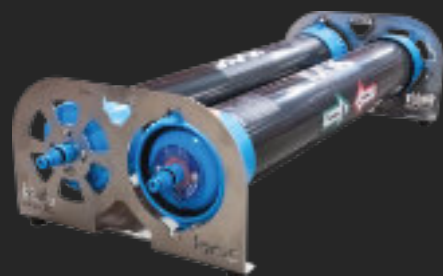

## Caddy™ DI System

The Caddy™ is a straight forward system that allows waterfed cleaning wherever there is access to a water supply. There are several Caddy™ configurations, from those that use only deionisation (eg. for soft-water areas).

### Ordering & Prices

Single DI  
Twin DI  
Triple DI



## TASK™

The Task™ Trolley is perfect for cleaning tasks in areas that have no access to water or hoses such as courtyards, or where trailing hoses cannot be used. The Task™ is also extremely useful for areas with restricted parking such as residential properties, busy high streets, city centres, etc. Includes 22Ah battery and 4Ah mains charger. 4hrs working time before recharge. 20-60 minutes working time (based on full tank).

### Ordering & Prices

Task 75-Litre Trolley



Includes flushing kit.

## Caddy™ In-Line Water Softener Kit

Ideal choice for window cleaners on the move, made for water softening onsite. The portable Caddy™ is easily carried and connects in-line between the water supply and the machine. Simply attach the in-line softener between the water supply and the machine, the softener will treat the water as it's used. Ionic offers a range of in-line softeners to suit all applications. Using the correct water softener will greatly improve performance and lifespan of the Reverse Osmosis filter.

### Ordering & Prices

Caddy™ In-Line Softener Kit  
Caddy™ Duplex In-Line Softener Kit  
Caddy™ Triple In-Line Softener Kit



## WallSoft™ In-line Water Softener Kit

A simple wall mounted water softener system that connects in-line between the water supply and the machine. Installed at the primary place of pure water production, WallSoft™ can be configured to soften even the hardest water.

### Ordering & Prices

WallSoft Softener Kit  
Twin WallSoft Softener Kit

# FOAMION

**Built for Soft Washing professionals. The Foamion™ provides the highest quality cleaning, mixed with ultimate efficiency and**

Foamion™ is a cost effective add on, foaming Soft Wash machine, and it works in conjunction with your existing Reach & Wash® System. Foamion™ gives the operative the option to mix any chemical product, i.e. Sodium Hypochlorite or Biocides at the point of use. This is a perfect way to apply treatments for algae infestations on render, plastics, or other external surfaces. Foamion™ can also be used to treat moss on roof tiles, or apply black spot remover for patios, paths, or driveways.

Using either hot or cold water (depending on the system it's fitted to), the on board air compressor gives the benefit of creating foam, allowing better chemical contact time and easier application. It has high and low chemical injector settings depending on the job at hand.

It holds 1 x 25L chemical drum, plus 2 x 5L chemicals of your choice. Max chemical mix 3/1, minimum 19/1.

In regards to Soft Washing, the Ionic ethos is about placing the integrity of the surface first. We manufacture products capable of maximising the efficiency of the chemicals being used.

This allows the operator to use the minimum amount of chemicals to achieve excellent results, whilst protecting your pocket and the environment!

Our sister company, the BWCA, teaches that:

**“You can always add more, but you can't take away!”**

Thus, our customers can achieve high quality finishes whilst protecting the surface, and importantly, the environment from high chemical concentrations, whilst being efficient in their work.



## Foamion™ Vehicle Mounted System

Foamion™ with 2x 150Ah  
Lead Acid Batteries & Charger

---

Foamion™ with 2 x 100Ah  
Lithium Ion Batteries & Charger

## Hi-Lo™ Pressure Pole

### Configurations

Hi-Lo™ Pressure Pole Full Kit

Hi-Lo™ Pressure Pole WFP Conversion Kit

*Hi-Lo™ Pressure Pole can be converted into a 32ft WFP for the additional cost of*



High-Pressure

Low-Pressure

## Constant Flow™ Starter Kit

Powerful, heavy duty foam cleaner for effective removal of algae. When used with Contact Foam cleaner produces a stable foam which rinses freely. Can be used with hot or cold water. The spray nozzle attaches to the Vertigo™ Quick Release waterfed pole head assembly. Can be supplied with RX hose adapter (for use with hozelock style fittings) or Rectus 021 series fittings.

### Ordering & Prices

Constant Flow Package - 24ft Hydra GF

Constant Flow Package - 28ft Hydra GF

Constant Flow Package - 32ft Hydra GF

Constant Flow Package - 24ft Hydra CF

Constant Flow Package - 28ft Hydra CF

Constant Flow Package - 32ft Hydra CF

Ionic Contact 5L

Ionic Contact 25L - *Collection only*



## Foamion™ Portable

The Foamion™ is a compact, battery-powered foaming system designed to give cleaning professionals better control, better coverage, and better results.

### Key features & benefits

- Portable lithium battery power**  
Advanced lithium battery technology delivers long-lasting, reliable power with no trailing cables or external power source.
- Compact and easy to transport**  
The small, lightweight design makes the Foamion™ easy to store, carry, and move between jobs.
- Standalone or system-mounted**  
Use the Foamion™ as a standalone unit or integrate it seamlessly with an existing Reach & Wash™ system.
- Effective foam application**  
By combining water (preferably pure water), chemical, and air, the Foamion™ produces a thick foam that clings to surfaces for extended dwell time.
- Reduced chemical waste**  
The foaming action minimises overspray, meaning more product stays on the surface and less is lost to runoff or drift.
- Wide range of applications**  
Ideal for cleaning windows, vehicles, and building exteriors where controlled, even chemical application is essential.

### Prices & Finance

#### Foamion™ Portable

Foamion™ Portable  
w/ 100Ah Lithium Battery (15A Charger)

Foamion™ Portable  
Stainless Steel Trolley



### Stainless Steel Trolley Easily manoeuvrable

Removable 'sack truck' style trolley is made of the same high quality, non-corroding stainless steel seen on all of our systems.

System can be stored in your vehicle. Simply slide the system out from its trolley and place in the desired position within your vehicle.

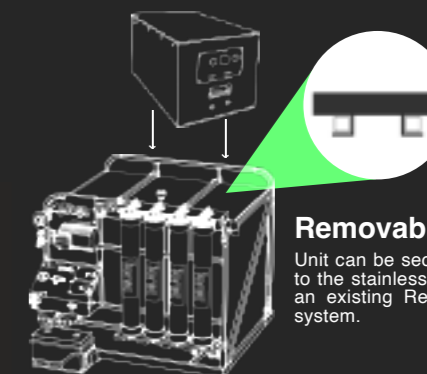

### Removable

Unit can be securely attached to the stainless steel frame of an existing Reach & Wash™ system.



## Proven. Upgraded. Exceptionally Profitable.

Since its release, the Roof Wand has become one of the most talked-about tools in professional exterior cleaning. Trusted by contractors across the UK, it's earned its reputation by delivering safe, effective roof cleaning from the ground, without scaffolding, access equipment, or unnecessary risk.

Now, with a series of carefully developed upgrades, the Roof Wand has become a multi-purpose, 3-in-1 roof cleaning system. It is no longer just a roof cleaning tool. It's a complete **Clean it. Treat it. Protect it.** system.



**Clean it.**  
High-volume water is delivered through the Roof Wand's turbo nozzles to safely and effectively remove moss, lichen, and surface contamination. The controlled flow and reach allow roofs to be cleaned thoroughly from the ground, reducing risk while maintaining excellent results.

**Treat it.**  
Once cleaned, swap to the softwash cleaning head to apply a biocide using a low-pressure pump. This kills remaining organic growth at the root and slows regrowth, extending the life of the clean and dramatically improving long-term results.

**Protect it.**  
With the latest upgrades, the Roof Wand can now apply a roof sealant using the built-in pump system. This final stage seals the surface, improves water run-off, and helps protect the roof against future damage and contamination.

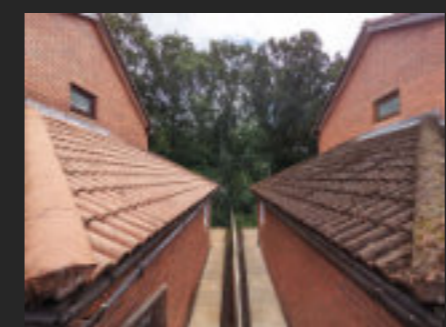

*The result is a roof restored as close to new condition as possible, without replacing a single tile.*



### 2026 Upgrades

- Additional rollers added to mast head. Improves handling of the carbon fibre wand pole, whilst reducing friction - boosting longevity.
- Anodised aluminium sleeves added to each connecting section of carbon fibre wand pole - reducing risk of accidental damage.
- Water/Sealant valve can now switch between feeding water or sealant through the 5LPM pump.



# Features

## Roof Cleaning

- **High water flow (21LPM)**, not high pressure
- Lightweight high-modulus carbon fibre pole (18m reach)
- Choice of **two or three turbo nozzles**
- Soft silicone covers help protect roof tiles
- **Remote controlled X & Y axis actuators (30° horizontal, 700mm vertical)** to easily move the cleaning head across the roof, maximising cleaning whilst reducing downtime.
- 6 x Stainless steel stabilisers
- Fan jets
- Solar brush & hoses
- **NEW to 2026** - Upgraded fulcrum rollers, roof sealant valve, anodised aluminium sleeves

## Biocide Application

- **Softwash spray head nozzle** with multiple diameter options
- **Mix valve** - point of use mixing of chemicals and water from either a tap or from your Reach & Wash® system.

## Roof Sealant Application

- **Sealant Spray Head Kit**
- Easily switch between feeding water or roof sealant through the **built-in 5LPM pump**

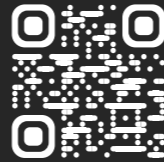

Scan the QR Code for more information!



### Roof Cleaner PLUS

High-strength BAC 50 for removing and preventing moss, algae, and mould. A simple spray-and-leave solution for long-lasting protection on external surfaces.



### Roof Sealant

Clear finish, water-based roof sealant. Provides a lasting water-repellent & protective layer to roof tiles.

## Basic

Ideal for roof cleaning only.  
*Pressure washer not included.*

Prices based on 5 year (60 month) finance package.

- Carbon Fibre Pole Assembly
- Mast Trolley (without Pump)
- Brushes + Hoses

## Standard

Ideal for roof cleaning and cleaning windows, solar panels, etc.  
*Pressure washer not included.*

Prices based on 5 year (60 month) finance package.

- Carbon Fibre Pole Assembly
- Mast Trolley (with 5lpm water pump + sealant valve)
- Brushes + Hoses

## Premium

Complete exterior cleaning system.  
Includes 5lpm water pump & compatible pressure washer.

Prices based on 5 year (60 month) finance package.

- Carbon Fibre Pole Assembly
- Mast Trolley (with 5lpm water pump + sealant valve)
- Brushes + Hoses
- Pressure Washer (Key Start)

### Additional extras:

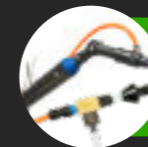

### Softwash spray head & mix valve

Enables mixing at the point of use and application of biocide chemicals

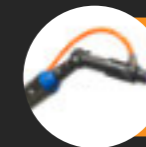

### Sealant Spray Head Kit

Enables application of roof sealant chemicals



### Mast Trolley Specifications

Pressure	6.9 bar (100 psi)
Flow	5 LPM (open flow)
Battery	12V, 22Ah (lead acid)
Wheels	Pneumatic
Actuators	12V
Dimensions	615D x 530W x 1100H
Weight	37kg (Dry), 107kg (Wet)

### Pressure Washer Specifications

Pressure	200 bar (2900 psi)
Flow	21 LPM
Engine	Honda GX390 (with oil alert)
Starter	Electric & recoil
Fuel Capacity	6.1 Litres
Dimensions	800L x 640W x 840H
Weight	66.5kg



# HYDRA™

Lightweight. Adaptive. Safer by Design.

## Protector™ Electrical Safety as Standard

Hydra™ poles now incorporate a second glass fibre section, creating an additional non-conductive barrier within the pole structure. This layered approach significantly reduces electrical risk when working near live services and provides genuine peace of mind on site.

Hydra™ waterfed poles offer verified electrical protection, with carbon fibre models rated safe up to **50,000 volts** and glass fibre models up to **80,000 volts**.



Watch a video of the Hydra™ pole in use



## Features

### Electrical Insulation

Verified electrical protection built into every pole for safer working near live services. Up to 50,000 volts protection using carbon poles & up to 80,000 volts for glass fibre.

### Patented clamp brake system

Pressing against the clamp when lowering acts as a brake, removing the need to touch the carbon section.

### Reduced pole wear

The patented clamp design pushes the lobes outwards, reducing friction and extending the life of the pole.

### Lightweight

Our 21ft carbon fibre pole weighs just 984g, making it easier to handle all day long.



Scan the QR Code to watch a video on electrical pole safety!



## Patented spring loaded clamps.

Hydra™ also retains Ionic's patented spring-loaded clamp system. Designed to deliver true anti-rotational performance, these clamps reduce wear on the pole sections while providing a secure, consistent lock every time. Less twist, less stress, and a longer working life from each pole.

Every detail of Hydra™ has been refined with one clear aim: to make high-reach window cleaning lighter, more controlled, and significantly safer, without compromise.



## Reach new heights.

With a maximum reach of up to 80ft, Ionic Hydra™ waterfed poles will allow you to safely reach and wash most exterior windows and surfaces before you will need further assistance. You may think that all that extra pole will become cumbersome and hard to use - that is simply not the case. Our longest pole only weighs 8kg, providing you with the light touch necessary for daily professional work.



### Grafter.



Non-curling monofilament nylon bristle brush and adjustable angle crank design.

Fit with a German/Euro thread style attachment.

### Swift.



Extremely robust aluminium build, designed for commercial cleaning.

Available with varying Gooseneck lengths for different size sills.

9" 24" 36"

Available with 14" & 18" brushes. Also available as flocked brush.



### Vertigo.



Tubeless angle crank design. Comes with either standard fitting or quick release brush head.

Quick Release Brush heads are available with three sizes of necks.



6"  
9"  
15"

Also available with blue flocked brush head for soft washing and microfibre pads.

Pencil Jets    Fan Jets

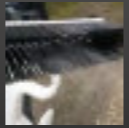
# PRICES & WEIGHTS

All prices include flyleads.



	Pole Only**	Grafter™ Head	Swift™ Head	Vertigo™ Standard Head	Vertigo™ Quick Release Head	Weights	
						Pole Only	Pole inc lightest brush/head
GLASS FIBRE	MiniPole (2 sections)					600g	1kg
	Hydra GF 17/5					1.29kg	912g
	Hydra GF 21/5					1.22kg	1.60kg
	Hydra GF 24/5					1.55kg	1.93kg
	Hydra GF 28/5					1.90kg	2.28kg
	Hydra GF 32/5					2.29kg	2.67kg
	Hydra CF21/5.2					984g	1.36kg
	Hydra CF 24/5.2					1.23kg	1.61kg
	Hydra CF 28/5.2					1.46kg	1.85kg
	Hydra CF 32/5.2					1.73kg	2.11kg
	Hydra CF 35/6.3					1.79kg	2.17kg
	Hydra CFP 35/6.3					1.79kg	2.17kg
	Hydra CF 40/6.3					2.10kg	2.48kg
	Hydra CFP 40/6.3					2.10kg	2.48kg
CARBON FIBRE	Hydra CF 45/6.3					2.46kg	2.84kg
	Hydra CFP 45/6.3					2.46kg	2.84kg
	Hydra CF 45/7.3					2.88kg	3.26kg
	Hydra CFP 45/7.3					2.88kg	3.26kg
	Hydra CF 55/7.3					3.93kg	4.31kg
	Hydra CFP 55/7.3					3.93kg	4.31kg
	Hydra CF 65/7.3					5.02kg	5.41kg
	Hydra CFP 65/7.3					5.02kg	5.41kg
	Hydra CFP 80/10.7					7.97kg	8.49kg

\*Hydra CFP models have even greater rigidity carbon fibre



# GET STARTED IN SOFTWASHING

The Constant Flow Starter Kit is the easiest way for an existing window cleaner to step into softwashing with confidence. Everything in the kit has been selected to remove complexity and guesswork, so you can focus on getting results and getting paid.

Designed to integrate seamlessly with your current setup, this kit allows you to safely and effectively apply softwash treatments to render, roofs, cladding, gutters, and more. No over-engineering. No unnecessary extras. Just a straightforward, professional solution that works from day one.

If you're already trusted by your customers, softwashing is a natural next step. It increases job value, opens up new services, and helps you make more from the same round.



## Training That Builds Confidence

To get the best results, we strongly recommend our Softwashing Training Course. Complete the theory online in your own time, then join us for a half-day practical session.

The training gives you the knowledge, confidence, and correct approach to start safely, price jobs properly, and avoid costly mistakes. You'll understand the fundamentals, apply them correctly, and leave ready to start making money straight away.

Enrol now at [bwca.co.uk](http://bwca.co.uk)

### Constant Flow Starter Kit



# BECOME A ROOF CLEANING PRO

The Roof Wand Training Course teaches you how to professionally clean, treat, and protect roofs without leaving the ground. Using the Roof Wand, you'll learn a safer, more efficient approach to roof cleaning that removes the need for ladders, scaffolding, or working at height.

The course is delivered by industry professional and inventor Steve Dunmore, giving you direct insight from the person who developed the system and the method behind it.



## Clean It. Treat It. Protect It.

This course goes beyond basic roof cleaning. You'll learn the full Clean it, Treat it, Protect it method, allowing you to offer a complete, high-value roof care service.

You'll be taught how to:

- Clean roofs effectively using the Roof Wand
- Apply biocide treatments for long-lasting results
- Apply roof sealants to protect and extend roof life

This approach delivers clear, visible results for your customers while significantly increasing the value of each job.



Enrol now at [bwca.co.uk](http://bwca.co.uk)

See how the water runs off the sealed tiles, but will completely saturate the non-sealed tiles.



# HOSE REELS



## Rapido™ Electric Hose Reel

Stackable 12v Electric Hose Reel with push button operation for super easy reeling. A second Rapido can be easily stacked on top.

### Ordering & Prices

Electric Hose Reel

Fitting is free as part of a system install, and £65 if a standalone install. Available with 6mm & 8mm hoesetails. £8 each.



1/2 inch Hi-Vis Hose

12.5MMHS



6mm RX Hose (100m)

RX6100



8mm RX Hose (100m)

RXH100

## Stainless Steel Hose Reel

Top quality stainless steel hose reel with wheels. Comes as Portable, Hand Carriable or Floor Mounted.

Available with 6mm, 8mm & 12mm hoesetail.

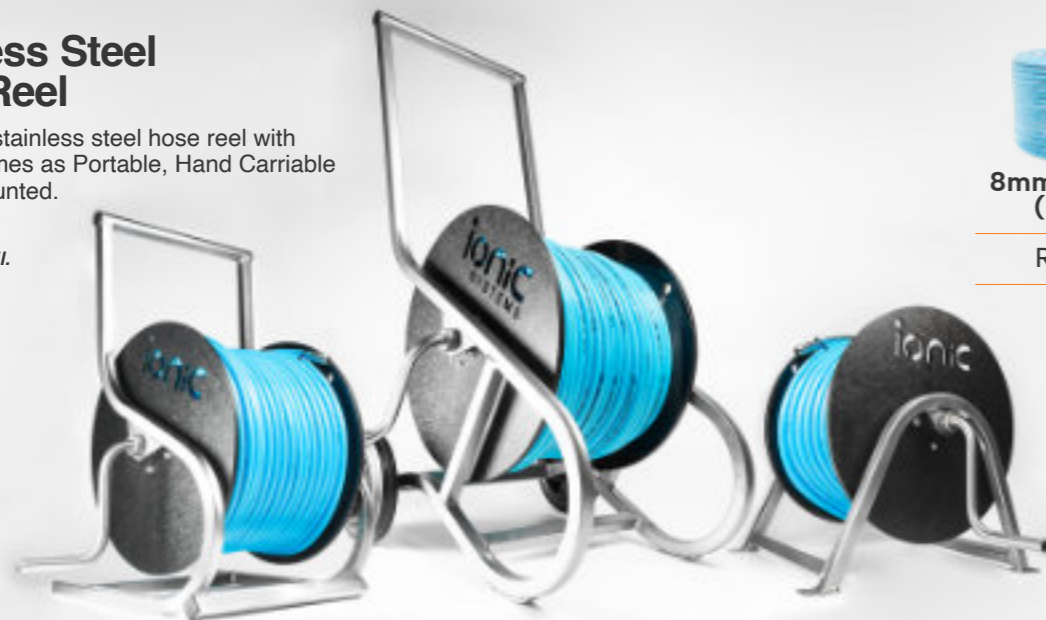

Hand Carriable Reel

Stainless Hose Reel

Floor Mounted Reel

Holds 50m of 1/2 inch hose or 100m of Ionic RX Hose.

Holds 50m of 1/2 inch hose or 100m of Ionic RX Hose.

Can be double stacked using a stacking frame (£125) & 2<sup>nd</sup> reel.



# GUTTER VACUUMS



## Vortex™ Gutter Vacuum - Premium Range

This powerful system has 50% more suction lift power than its nearest rival. Three industrial strength vacuum motors giving huge suction power of 150 inches of water lift.

**Kit Includes:** Vortex Vacuum, drum with drain hose and sieve basket, elite 50mm carbon fibre clamped poles, vac release pole, elite hairpin tool holder, 7.5m wire reinforced suction hose, vac to hose cuff, hose to pole cuff, a selection of end attachment tools for various applications, and a pole and accessory carry bag. Available in 3 height reaches.

### Pole options:

4 Poles 20ft/6m Reach

6 Poles 30ft/9m Reach

8 Poles 40ft/12m Reach

## Vortex Piccolo™ Gutter Vacuum with Cyclonic Side Entry

Safe and easy gutter vacuuming with this wet and dry vacuum, ideal for domestic use, especially high reach applications. Now with cyclonic side entry vacuum. Available with 44mm push fit or 50mm clamped poles.

### Push Fit Pole Kit Includes:

Vortex Piccolo (with 50mm cyclonic vac port), 44mm standard carbon fibre poles, 5m wire reinforced suction hose, vac to hose cuff, hose to pole cuff, a selection of end attachment tools for various applications, 135 and 180 degree blue silicone flexi neck tool holders, and a pole and accessory carry bag. Available in 3 height reaches.

### Clamped Pole Kit Includes:

50mm clamped carbon fibre poles, vac release pole, elite hairpin tool holder, 5m wire reinforced suction hose, vac to hose cuff, hose to pole cuff, a selection of end attachment tools for various applications, 135 and 180 degree blue silicone flexi neck tool holders, and a pole and accessory carry bag. Available in 3 height reaches.

### Push-fit Pole options:

4 Poles 20ft/6m Reach

6 Poles 30ft/9m Reach

7 Poles 34ft/10.5m Reach

### Clamped Pole options:

4 Poles 20ft/6m Reach

6 Poles 30ft/9m Reach

7 Poles 34ft/10.5m Reach



\*\*non-recordable system shown in image.

## Camera Kit

Designed for real time gutter clearance and high level inspection. Built with a 4.3" screen and sleek look, perfect for gutter cleaning professionals.

### Options:

Non-recordable system

Recordable system

## Vortex™ Gutter Vacuum

Vacuum has three Industrial strength vacuum motors giving huge suction power of 100 inches of water lift.

**Kit Includes:** Vortex Vacuum, 50mm clamped carbon poles, vac release pole, elite hairpin tool holder 7.5m wire reinforced suction hose, vac to hose cuff, hose to pole cuff, a selection of various end attachment tools for various applications, and a pole and accessory carry bag. Choice of 3 height reaches.

### Pole options:

4 Poles 20ft/6m Reach

6 Poles 30ft/9m Reach

8 Poles 40ft/12m Reach

\*\*Images of all vacuum packages (including attachment tools) can be found on our website.





**Quality. Safety. Efficiency.**

**Visit us on our Website!**

**Ionic Systems Ltd**

7-8 Westerngate  
Hillmead Enterprise Park  
Swindon, Wiltshire  
SN5 5WN

**Telephone:** (01793) 871386

**Email:** [info@ionicsystems.com](mailto:info@ionicsystems.com)



**Discover**

more on our social media channels



**[www.ionicsystems.com](http://www.ionicsystems.com)**

Copyright 2026, Ionic Systems Ltd. All finance examples are for information only. Terms & conditions apply. All prices exclude VAT unless otherwise indicated. E&OE - Errors & Omissions excepted.